

REAR SUSPENSION 後懸吊系統

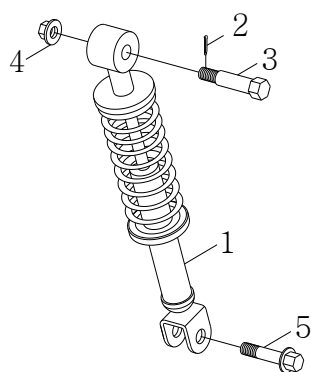

NO. 項目	PARTS NO. 零件號碼	PARTS NAME 零件名稱		QTY 用量	NOTE 備註
1	32210-SK2-00	SHOCK ABSORBER ASS'Y, REAR	後緩衝器總成	1	
2	90240-18016-B	COTTER PIN 1.8*16	開口銷	1	
3	94716-08039-B	BOLT	後緩衝器固定軸	1	
4	95401-081208-B	NUT, FLANGE	凸緣螺帽	1	
5	96414-08035-B	BOLT, FLANGE	凸緣螺栓	1	

REAR BRAKE 後制車系統

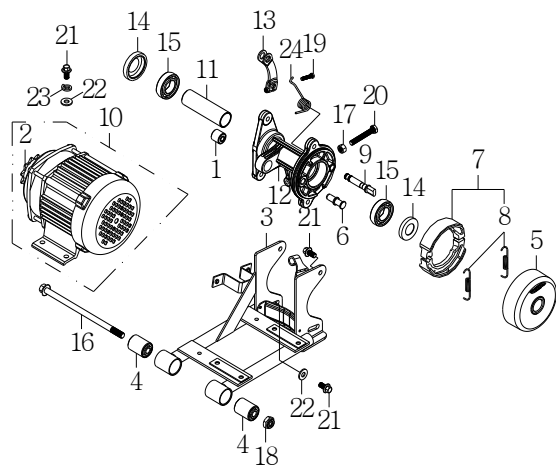

NO. 項目	PARTS NO. 零件號碼	PARTS NAME 零件名稱		QTY 用量	NOTE 備註
1	15116-NAF-00	BUSH, REAR SHOCK ABSORBER	後緩衝器襯套	1	
2	25711-EK2-00	SPROCKET DRIVE 415-14T	驅動鏈輪	1	
3	32100-EK2-00	REAR ARM	擺動臂	1	
4	32116-GKO-00	BUSH 10*28.1*36/40	搖臂襯套	2	
5	32320-SK2-00	HUB, REAR BRAKE	後制車轂	1	
6	32326-SK2-00	PIN, PIVOT	後制車固定軸	1	
7	32345-SK2-00	BRAKE SHOE KIT	後制車塊組	1	
8	32346-SK2-00	SPRING, TENSION	後制車拉伸彈簧	2	
9	32351-SK2-00	CAMSHAFT	後制車凸輪軸	1	
10	35850-EK2-00	MOTOR ASSY	馬達整體	1	
11	42815-SK2-00	SPACER, BEARING	後輪隔管	1	
12	42881-SK2-00	HUB, REAR	後輪轂	1	
13	45855-SK9-00	LEVER, CAMSHAFT	前制車搖臂	1	
14	93110-30477	OIL SEAL 30*47*7	油封	2	
15	9332C-254712	BALL BEARING 6005CO	滾珠軸承	2	
16	94610-10184-B	BLOT, FLANGE	吊架固定軸	1	
17	95201-081207-B	NUT, HEXAGON	六角螺帽	1	
18	95311-101710-B	NUT, NYLON	尼龍螺帽	1	
19	96210-05025-B	BOLT, HEXAGON	六角螺栓	1	
20	96210-08055-B	BOLT, HEXAGON	六角螺栓	1	
21	96414-08016-B	BOLT, FLANGE	凸緣螺栓	8	
22	97201-082420-B	WASHER, PLATE 8.7*24*2.0	平面墊圈	6	
23	97301-081520-B	WASHER, SPRING	彈簧墊圈	4	
24	97508-25155-B	SPRING TORSION	後制車扭轉彈簧	1	

FRAME 車架

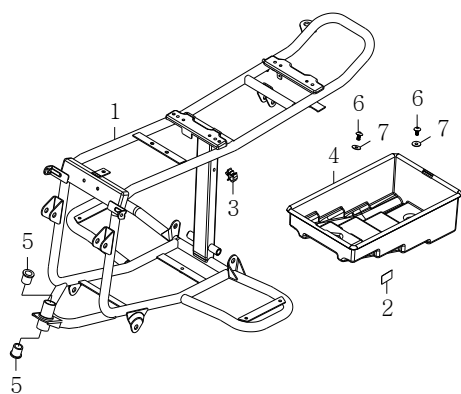

NO. 項目	PARTS NO. 零件號碼	PARTS NAME 零件名稱	QTY 用量	NOTE 備註
1	41110-EK2-00	FRAME COMP	1	
2	56377-EK2-00	BATTERIES IN SERIES CANON	1	
3	61393-EK2-00	CABLE CLIP	1	F3216
4	62126-EK2-00	BATTERY BOX	1	
5	93330-152118	BUSH, SOLID	2	
6	96318-06012-G	SCREW, PAN HEAD	2	
7	97321-061825-G	WASHER, FLANGE	2	

STEERING 轉向裝置

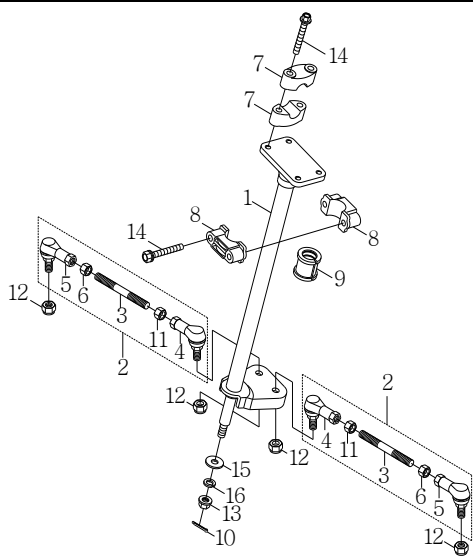

NO. 項目	PARTS NO. 零件號碼	PARTS NAME 零件名稱	QTY 用量	NOTE 備註
1	42101-SK2-00	COLUMN, STEERING	1	轉向桿
2	42140-SK2-00	ROD, TIE ASSY	2	連桿總成
3	42141-SK2-00	ROD, TIE	2	連桿
4	42142-SK2-00	JOINT, UNIVERSAL R	2	萬向接頭 右
5	42143-SK2-00	JOINT, UNIVERSAL L	2	萬向接頭 左
6	42146-SK2-00	NUT	2	連桿螺帽
7	46125-SK2-00	HOLDER, HANDLE UPPER	4	把手上固定座
8	46411-SK2-00	BEARING, STEERING	2	轉向桿固定座
9	46417-SK2-00	PU BUSH	1	PU襯套
10	90240-23020-B	COTTER PIN 2.3*20	1	開口銷
11	95201-101408-B	NUT, HEXAGON	2	六角螺帽
12	95311-101710-B	NUT, NYLON	4	尼龍螺帽
13	95401-101409-B	NUT, FLANGE	1	凸緣螺帽
14	96414-08050-B	BOLT, FLANGE	6	凸緣螺栓
15	97201-102620-B	WASHER, PLATE	1	平面墊圈
16	97301-101720-B	WASHER, SPRING	1	彈簧墊圈

FRONT SUSPENSION 前懸吊系統

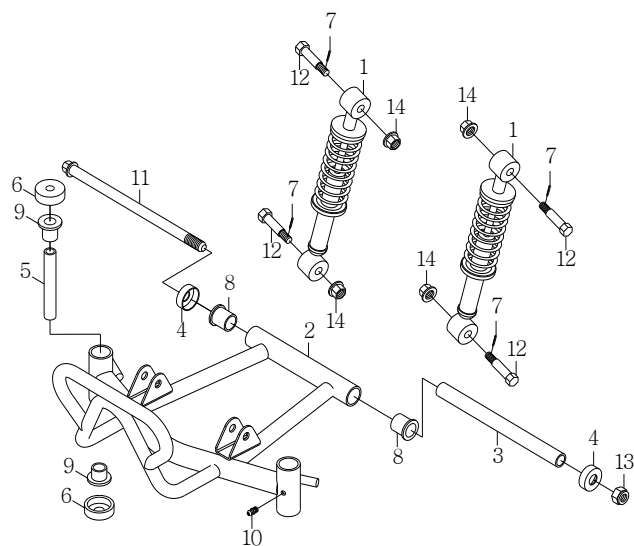

NO. 項目	PARTS NO. 零件號碼	PARTS NAME 零件名稱		QTY 用量	NOTE 備註
1	42126-SK2-00	SHOCK ABSORBER ASS'Y	前緩衝器總成	2	
2	42161-SK2-01	FRT, ARM	前搖臂	1	
3	42173-RAM-00	COLLAR	搖臂軸襯	1	
4	42183-RAM-00	COVER, THRUST	塵封蓋	2	
5	45825-SK9-00	COLLAR	轉向關結座軸襯	2	
6	45827-SK9-00	COVER, THRUST	塵封蓋	4	
7	90240-18016-B	PIN COTTER 1.8*16	開口銷	4	
8	93330-152118	BUSH, SOLID	羅龍滑動軸承	2	
9	93330-172330	BUSH, SOLID	羅龍滑動軸承	4	
10	94340-06010-B	NIPPLE, GREASE	黃油嘴	2	
11	94610-10200-B	BLOT, FLANGE	前搖臂固定軸	1	
12	94716-08039-B	BLOT	後緩衝器固定軸	4	
13	95311-101710-B	NUT, NYLON	尼龍螺帽	1	
14	95401-081208-B	NUT, FLANGE	凸緣螺帽	4	

FRONT WHEEL 前輪

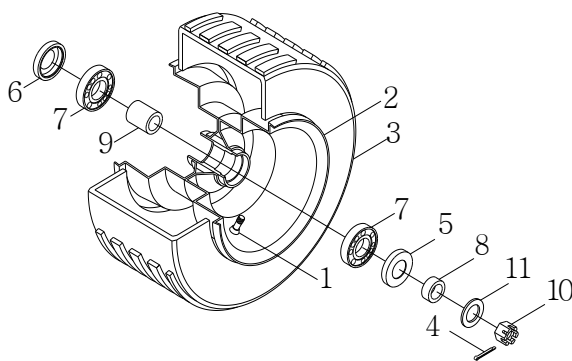

NO. 項目	PARTS NO. 零件號碼	PARTS NAME 零件名稱	QTY 用量	NOTE 備註
1	42570-RAM-00	VALVE, RIM	2	氣門嘴
2	42580-SK2-00	WHEEL, FRONT	2	前輪圈
3	42590-SK2-00	TIRE, FRONT 145/70-6	2	輪胎
4	90240-29025-B	COTTER PIN 2.9*25	2	開口銷
5	93110-20355	OIL SEAL 20*35*5	2	油封
6	93110-22357	OIL SEAL 22*35*7	2	油封
7	9332C-153511	BALL BEARING 6202 CO	4	滾珠軸承
8	93510-152008-B	COLLAR	2	前輪轂側隔管
9	93510-152233-B	SPACER, BEARING	2	前輪間隔管
10	95321-142215-C	NUT, CASTLE	2	有槽螺帽
11	97201-142620-C	WASHER, PLATE 14.7*25.7*2	2	平面墊圈

REAR WHEEL 後輪

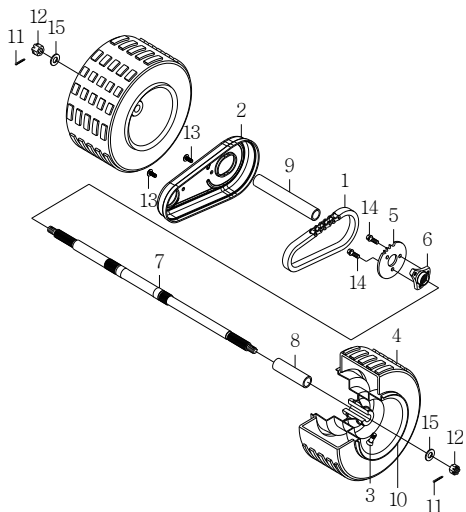

NO. 項目	PARTS NO. 零件號碼	PARTS NAME 零件名稱	QTY 用量	NOTE 備註
1	25743-EK2-00	CHAIN 415H*42L	1	鏈條
2	32191-EK2-00	DRIVE CHAIN CASE	1	鏈條蓋
3	42570-RAM-00	VALVE, RIM	2	氣門嘴
4	42590-SK2-00	TIRE, FRONT 145/70-6	2	輪胎
5	42812-SK2-00	SPROCKET, DRIVEN 415-21T	1	傳動鏈輪
6	42821-SK2-00	DRIVE SPROCKET BASE	1	傳動鏈輪座
7	42835-EK2-00	AXLE, WHEEL	1	後輪軸
8	42836-EK2-00	SPACER, BEARING L	1	後輪左隔管
9	42837-EK2-00	SPACER, BEARING R	1	後輪右隔管
10	42880-SK2-00	TIRE, REAR	2	後輪圈
11	90240-29025-B	COTTER PIN 2.9*25	2	開口銷
12	95321-142215-C	NUT, CASTLE	2	有槽螺帽
13	96318-06012-G	SCREW, PAN HEAD	2	十字孔頭螺絲
14	96416-08012-C	BOLT, FLANGE	3	凸緣螺栓
15	97201-143430-B	WASHER, PLATE 14.3*34*3	2	平面墊圈

STEERING KNUCKLE 轉向關節座

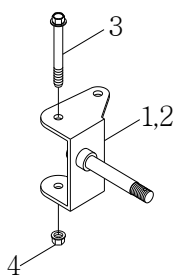

NO. 項目	PARTS NO. 零件號碼	PARTS NAME 零件名稱		QTY 用量	NOTE 備註
1	45861-SK2-00	KNUCKLE, STEERING L	左前轉向關節座	1	
2	45866-SK2-00	KNUCKLE, STEERING R	右前轉向關節座	1	
3	94610-10103-B	BOLT, FLANGE	轉向關節固定軸	2	
4	95311-101710-B	NUT, NYLON	尼龍螺帽	2	

STEERING HANDLE CABLE 轉向把手、鋼索

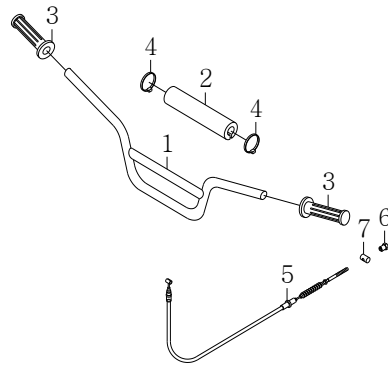

NO. 項目	PARTS NO. 零件號碼	PARTS NAME 零件名稱		QTY 用量	NOTE 備註
1	46110-SK2-00	HANDLEBAR	把手整體	1	
2	46117-SK2-00	PROTECTOR	把手橫桿護套	1	
3	46240-SK2-00	GRIP	握把	2	
4	61135-SK2-00	BAND, CORD	束帶	2	
5	61320-SK2-00	CABLE, BRAKE	後剎車鋼索	1	
6	61379-NAF-01	NUT, ADJUST	調整螺帽	1	
7	61389-NAF-00	PIN, FIXTURE	導線固定塊	1	

FRONT FENDER, WARNING 前土除、警告標示 (only for EK2)

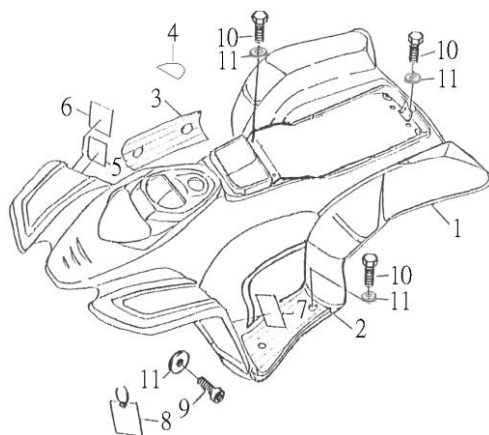

NO. 項目	PARTS NO. 零件號碼	PARTS NAME 零件名稱	QTY 用量	NOTE 備註
1	51171-SK2-00	SIDE COVER	1	側蓋
2	53483-SK2-00	MAT L	1	左踏板墊
3	53484-SK2-00	MAT R	1	右踏板墊
4	56378-EK2-00	LABEL CHARGING TIME ADVICE	1	建議充電時機貼紙
5	56576-SK2-00	LABEL WARNING 3 (Tire)	1	胎壓規範
6	56578-SK2-00	LABEL WARNING 2 (Age)	1	年齡規範
7	56781-SK2-00	LABEL WARNING 1 (Operation)	1	騎乘規範
8	56782-RAM-00	ATV WARN.TAG SPORT	1	娛樂規範 (吊卡)
9	96318-06012-G	SCREW, PAN HEAD	2	十字孔頭螺絲
10	96318-06015-G	SCREW, PAN HEAD	8	十字孔頭螺絲
11	97321-061825-G	WASHER, FLANGE	10	凸緣墊圈

FRONT FENDER, WARNING 前土除、警告標示 (only for EK3)

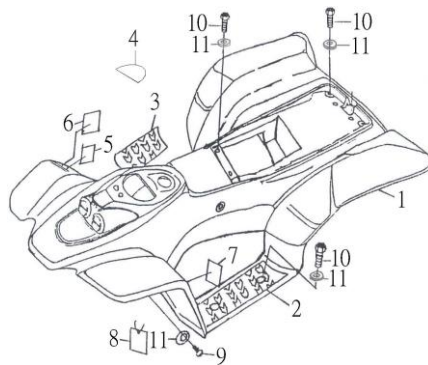

NO. 項目	PARTS NO. 零件號碼	PARTS NAME 零件名稱	QTY 用量	NOTE 備註
1	51171-SK3-00	SIDE COVER	1	without headlight
	51171-SK3-01	SIDE COVER	1	with headlight
2	53483-SK2-00	MAT L	1	
3	53484-SK2-00	MAT R	1	
4	56378-EK2-00	LABEL CHARGING TIME ADVICE	1	
5	56576-SK2-00	LABEL WARNING 3 (Tire)	1	
6	56578-SK2-00	LABEL WARNING 2 (Age)	1	
7	56781-SK2-00	LABEL WARNING 1 (Operation)	1	
8	56782-RAM-00	ATV WARN.TAG SPORT	1	
9	96318-06012-G	SCREW, PAN HEAD	2	
10	96318-06015-G	SCREW, PAN HEAD	8	
11	97321-061825-G	WASHER, FLANGE	10	

HEADLIGHT 前燈(only for EK3)

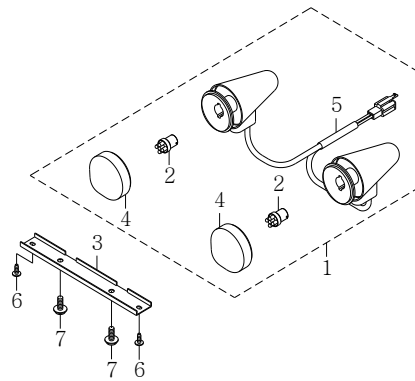

NO. 項目	PARTS NO. 零件號碼	PARTS NAME 零件名稱	QTY 用量	NOTE 備註
1	55300-EK3-00	HEAD LIGHT ASSY	1	前燈總成
2	55314-EK3-00	BULB, HEAD LIGHT	2	前燈燈泡
3	55315-SK3-00	STAY, HEAD LIGHT	1	前燈固定座
4	55320-SK3-00	LENS ASSY	2	前燈單元總成
5	55340-SK3-00	SOCKET CORD ASSY	1	燈座總成
6	96112-41218-K	SCREW, TAPPING	2	自攻螺絲
7	96318-06012-G	SCREW, PAN HEAD	2	十字孔頭螺絲

SEAT 座墊

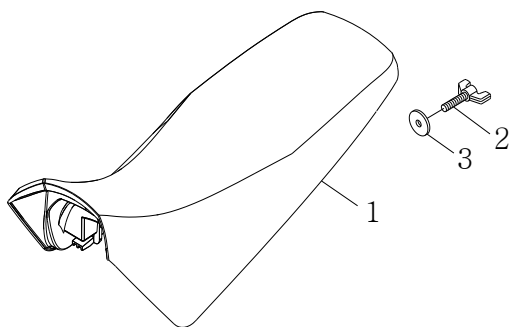

NO. 項目	PARTS NO. 零件號碼	PARTS NAME 零件名稱	QTY 用量	NOTE 備註
1	52730-SK2-00	SINGLE SEAT ASSY	1	單人座墊總成
2	94716-06016-C	BOLT, BUTTERFLY	1	蝶形螺栓
3	97201-062220-B	WASHER, PLATE	1	平面墊圈

WIRE HARNESS 主配線配線

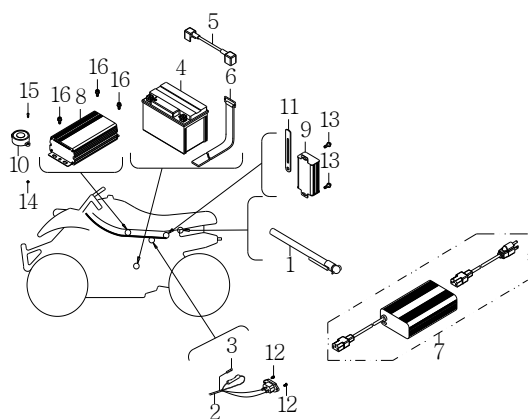

NO. 項目	PARTS NO. 零件號碼	PARTS NAME 零件名稱	QTY 用量	NOTE 備註
1	56190-RAM-00	GAUGE, AIR	1	胎壓計
2	61120-EK2-00	WIRE, HARNESS	1	主配線總成
3	61151-NAF-00	FUSE	1	保險絲
4	62100-EK2-00	BATTERY ASSY REC22-12	4	蓄電池總成
	62100-EK2-01	BATTERY ASSY PE12V18	4	蓄電池總成
5	62110-EK2-00	CABLE, BATTERY	3	蓄電池導線
6	62112-EK2-00	BAND, BATTERY	1	電瓶束套
7	62160-EK2-00	CHARGER	1	充電器
8	62250-EK2-00	CONTROLLER	1	控制器
9	62360-EK2-00	12V CONVERTER	1	12V轉換器
10	62370-EK2-00	BUZZER	1	蜂鳴器
11	91112-10100-B	FOLDER	1	導線軟勾
12	94712-03008-C	SCREW, FLAT HEAD	2	十字孔埋頭螺栓
13	94714-04012-B	BOLT	2	十字孔凸緣螺栓
14	95201-030603-K	NUT, HEXAGON	1	六角螺帽
15	96310-03008-K	SCREW, PAN HEAD	1	十字孔頭螺絲
16	96612-05012-B	BOLT, HEXAGON WITH WASHER	3	六角十字穴螺栓附墊圈

HANDLE SWITCH, LEVER 把手開關、拉桿

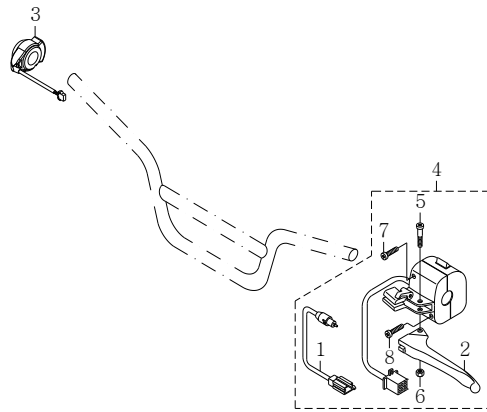

NO. 項目	PARTS NO. 零件號碼	PARTS NAME 零件名稱	QTY 用量	NOTE 備註
1	45890-EK2-00	FRONT STOP SWITCH	1	前剎車燈開關
2	62912-SK2-00	LEVER, L	1	左拉桿
3	62920-EK2-00	THROTTLE SWITCH	1	節流開關
4	62930-EK2-00	HANDLE SWITCH ASSY L	1	左把手開關總成
5	94710-05023-G	BOLT, LEVER	1	拉桿螺栓
6	95311-050805-G	NUT, NYLON	1	尼龍螺帽
7	96310-05020-G	SCREW, PAN HEAD	1	十字孔頭螺絲
8	96310-05025-G	SCREW, PAN HEAD	1	十字孔頭螺絲

REMOTE CONTROL ENGINE STOP SWITCH 遙控器組(Accessory)

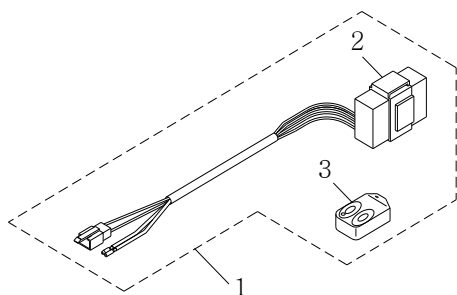

NO. 項目	PARTS NO. 零件號碼	PARTS NAME 零件名稱	QTY 用量	NOTE 備註
1	62330-EK2-00	REMOTE CONTROL ASSY	1	遙控器組
2	62331-EK2-00	RECEPTION INSTRUMENT	1	接收器
3	62332-EK2-00	REMOTE CONTROL	1	遙控器